

AIR COOLED - NON WATER HEATING DEHUMIDIFIERS

DCA 2500TV, DCA 3000TV

WATER HEATING ASSIST DEHUMIDIFIERS

DCA 2500TVWH, DCA 3000TVWH

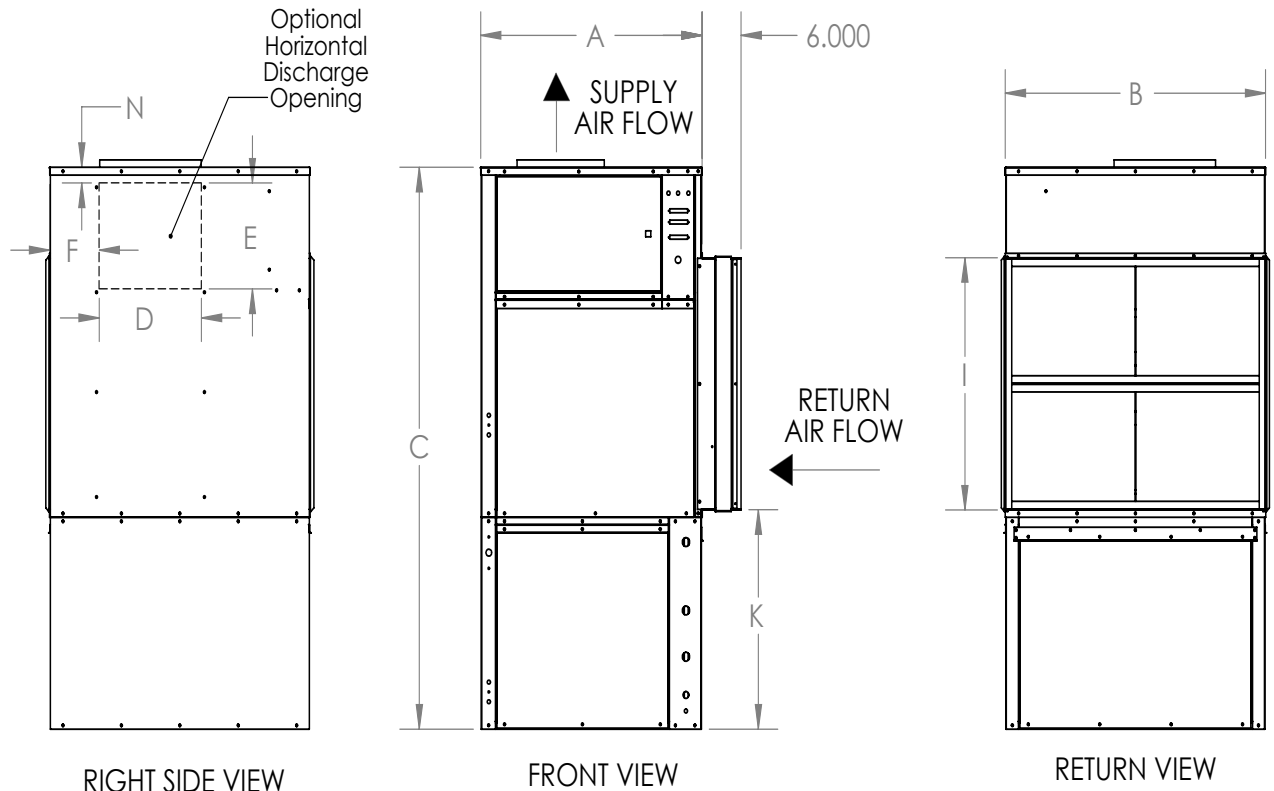
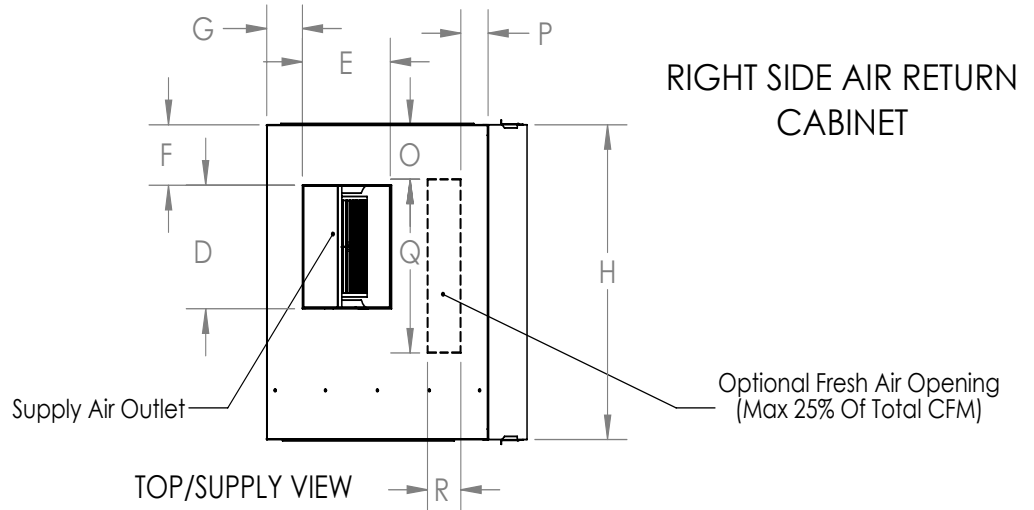

PHYSICAL DIMENSIONS

	A	B	C	D	E	F	G	H	I	J	K	N	O	P	Q	R
DCA 2500TV, DCA 2500TVWH	34	40	71.6	15 5/8	13 1/2	7 5/8	5	40 1/8	32 1/8	Not used	28	2	7	6 1/2	22	5
DCA 3000TV, DCA 3000TVWH	34	40	71.6	15 5/8	13 1/2	7 5/8	7 1/2	40 1/8	32 1/8	Not used	28	2	7	4 1/4	22	5

Cautions: All dimensions are in inches and are subject to change without notice.

AIR COOLED - NON WATER HEATING DEHUMIDIFIERS
DCA 2500TV, DCA 3000TV
WATER HEATING ASSIST DEHUMIDIFIERS
DCA 2500TVWH, DCA 3000TVWH

SERVICE ACCESS

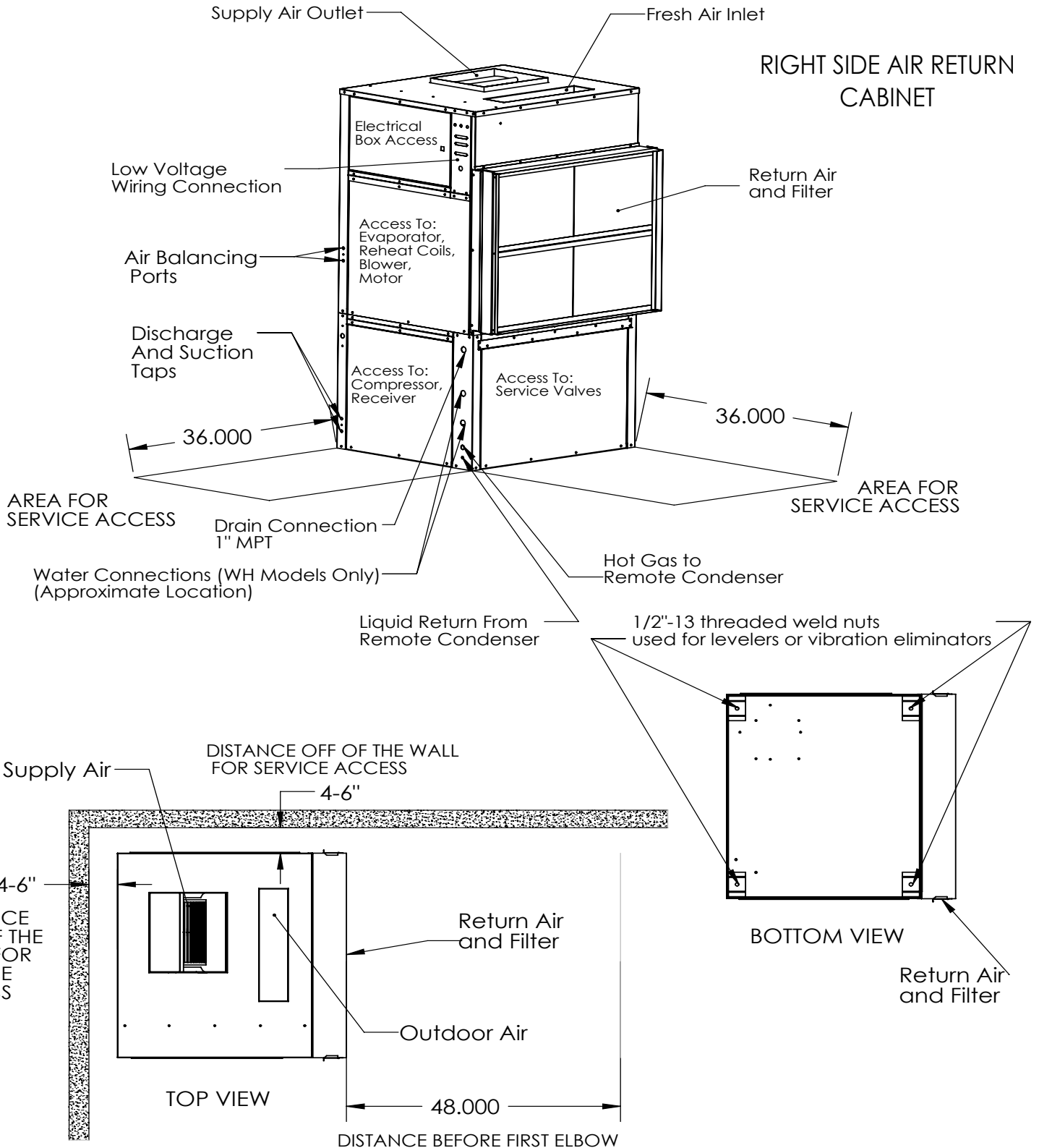

Cautions: All dimensions are in inches and are subject to change without notice.